

CAD FILE:

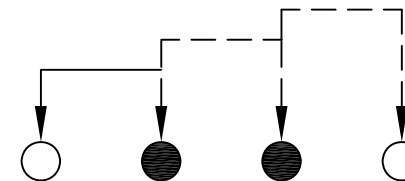

**SCHEMATIC (NON-SHORTING)**

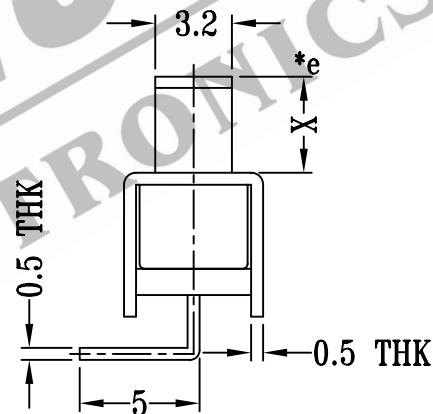
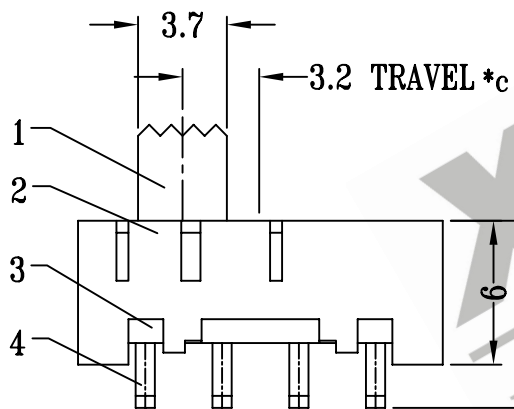
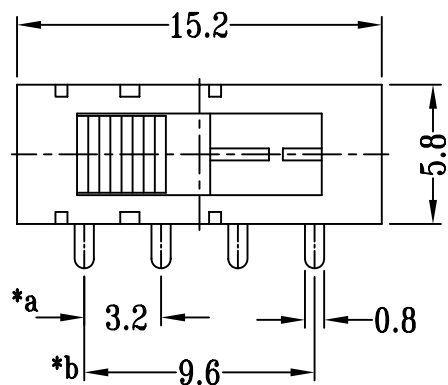
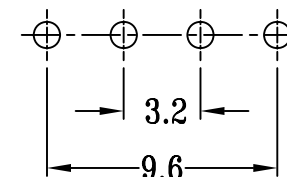

**P.C.B LAYOUT**

注:带"\*"表示关键尺寸(5个)

				TOLERANCE UNLESS SPECIFIED		SHENZHEN XIEJIA ELECTRONICS CO.,LTD.						
				WITHIN: 1.5±0.1mm		ISSUE	DATE	DESCRIPTIONS OF REVISION		APPD.		
				OVER: 1.5±0.2mm								
8						TITLE : VERTICAL SLIDE SWITCH				UNIT : mm	DRWG NO.: XJ-DR-SS13F30-00	
7	STEEL BALL	STEEL	2	NATURAL	MODEL: SS-13F30				SCALE: 3:1	DWN.	ZHOUYU	2003-9-21
6	SPRING	SUS WIRE	1	TEMPER	ALL MATERIALS MUST BE COMPLIANT TO ROHS					CHK'D	FANGYING	2003-9-21
5	CONTACT CLIP	PBS	1	Ag CLAD							APPD.	KANGXINAN
4	TERMINAL	BRASS STRIP	4	Ag PLATED OVER Ni PLATED								
3	BASE	PHENOLIC RESIN	1	NATURAL								
2	FRAME	STEEL STRIP	1	Ni PLATED								
1	KNOB	POM	1	BLACK								
NO.	PARTS	MATERIALS	Q'TY	FINISH					APPD.	KANGXINAN	2003-9-21	